

DOJ Compact High-Angle Constant Velocity Joint

Lightweight and compact with a maximum operating angle of 30°DOJ



Features

- External dimensions: one size more compact (approximately 4%) compared to the current 30° DOJ
- Weight: approximately 6% lighter
- Strength and durability: improved actual strength and durability through optimization of track contact angle/contact ratio, and cage offset

Applications

- SUVs and other vehicles that require greater operating angles

Typical application

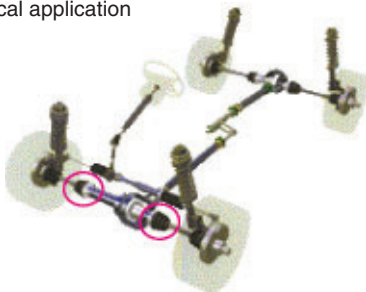

Structure

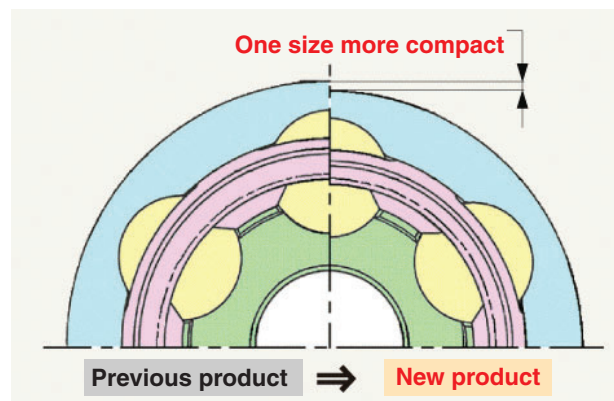

PTJ High-Angle Low-Vibration Constant Velocity Joint

The PTJ low-vibration constant velocity joint boasts the world's highest level of NVH performance^{※1} and achieves a maximum operating angle of 30° for the first time in the world^{※2}



※1 Performance associated with vehicle noise and vibration. ※2 In the low-vibration tripod CVJ category

Features

- **Extended operating angle range that ensures low vibration**
From 15° to 17°

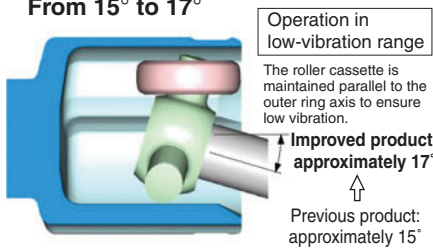

- **Enlarged operating angle range**
Operation possible up to 30°

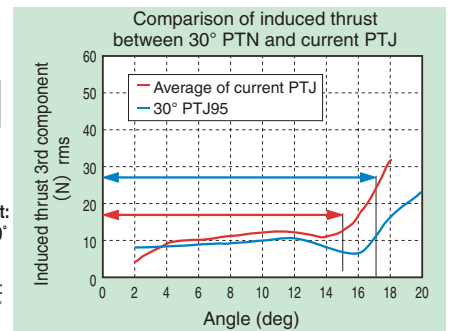
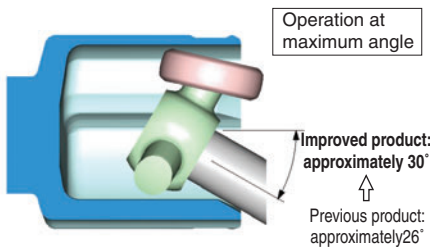

Structure

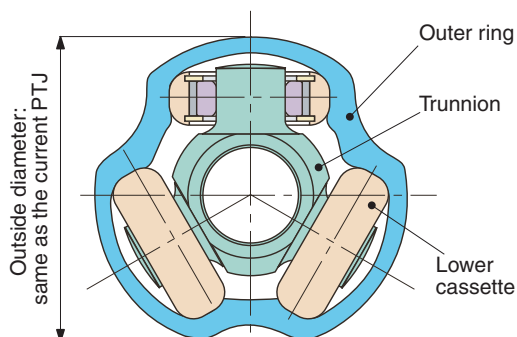

Applications

- **Crossover SUVs and other vehicle types that require greater operating angle and lower vibration**
Example of application

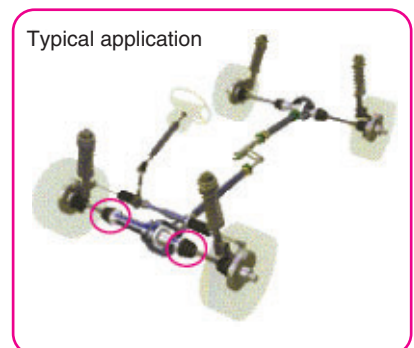

Super-Wide Operating Angle (54°) Fixed CVJ (TUJ)

The world's first fixed CVJ capable of a super-wide operating angle (θ max. = 54°)

Results of a case study that assumes a 4° increase in the operating angle with a fixed joint on an ordinary medium-sized FF vehicle

Approximately 70 cm (13%) decrease in the minimum turning radius of the vehicle
(when the wheelbase is the same as a conventional CVJ)

Approximately 40 cm (15%) increase in the wheelbase
(when the minimum turning radius is the same as a conventional CVJ)



Example of use

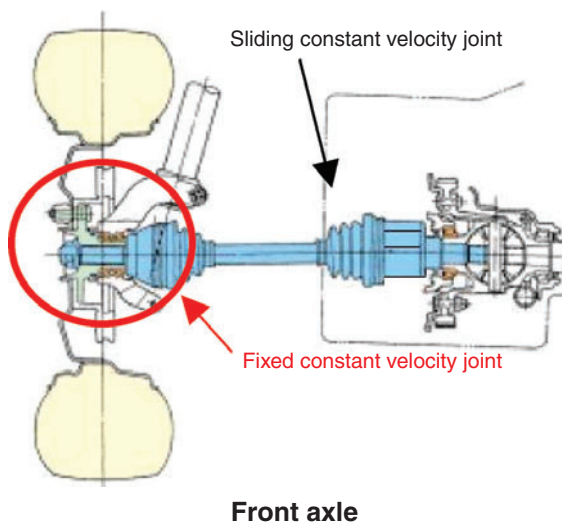

Features

- Maximum operating angle (θ max): 54° (current UJ: 50°)
- Outer ring outside dia.: Same as with UJ
- Mechanical strength, durability: Equivalent to those with UJ

Applications

- Large-sized and medium-sized FF and 4WD vehicles boasting smaller minimum turning radius

Ultra-Low Torque Tapered Roller Bearing

Significantly lower running torque
(1/2 that of previous tapered roller bearing in the same class),
without loss in bearing life and rigidity



Features

- Realization of lower torque: 1/2 that of previous bearing
- Compact bearing size: 10% or greater reduction of outside bearing diameter (same life and rigidity compared to previous bearing)

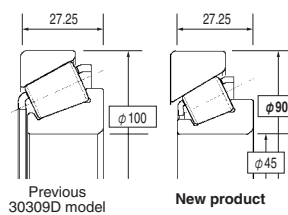

Engineering challenges and solutions

Challenge 1: Realization of lower torque

Means for realization: Implementation of optimization in design

Adoption of a new cage form with reduced oil stirring resistance

Challenge 2: Maintain bearing life comparable to that of the previous bearing

Means for realization: Adoption of FA heat treatment

When lubricated with clean oil, the new product boasts a bearing life 2.8 times as long as that of the 4T product.

Challenge 3: Maintain rigidity comparable to that of the previous bearing

Means for realization: Adoption of a high load capacity design

The cage is situated near the outer ring and a maximum possible number of rollers are incorporated.

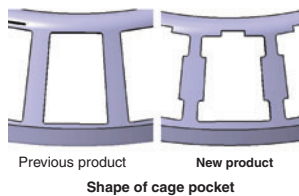
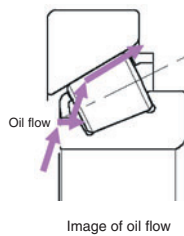

Performance

Torque measurement result

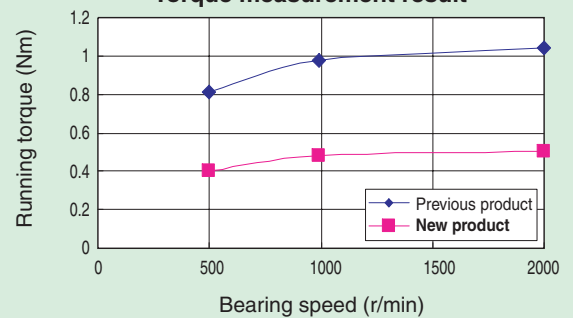

Running torque is 1/2 as low as the previous product at a practical speed range of 500–2000 r/min.

Bearing rigidity calculation result

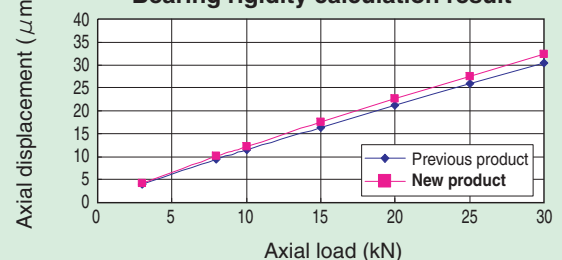

The new product has rigidity nearly equivalent to that of the previous product

High Load Capacity Tapered Hub Bearing for SUVs

Realization of 20% longer bearing life and 7% higher rigidity in the same amount of space

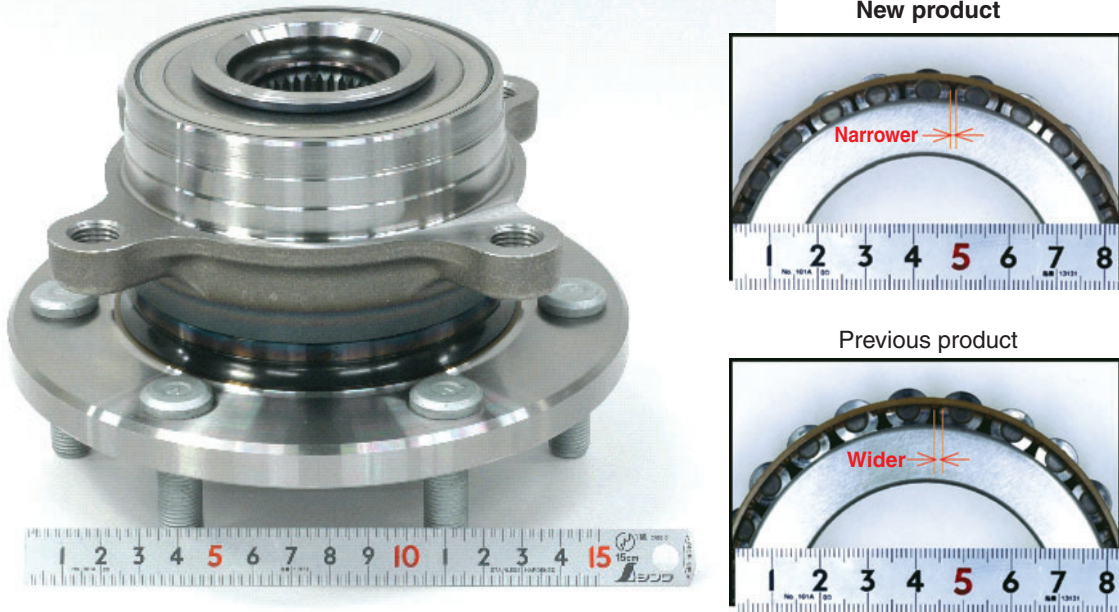

Structure

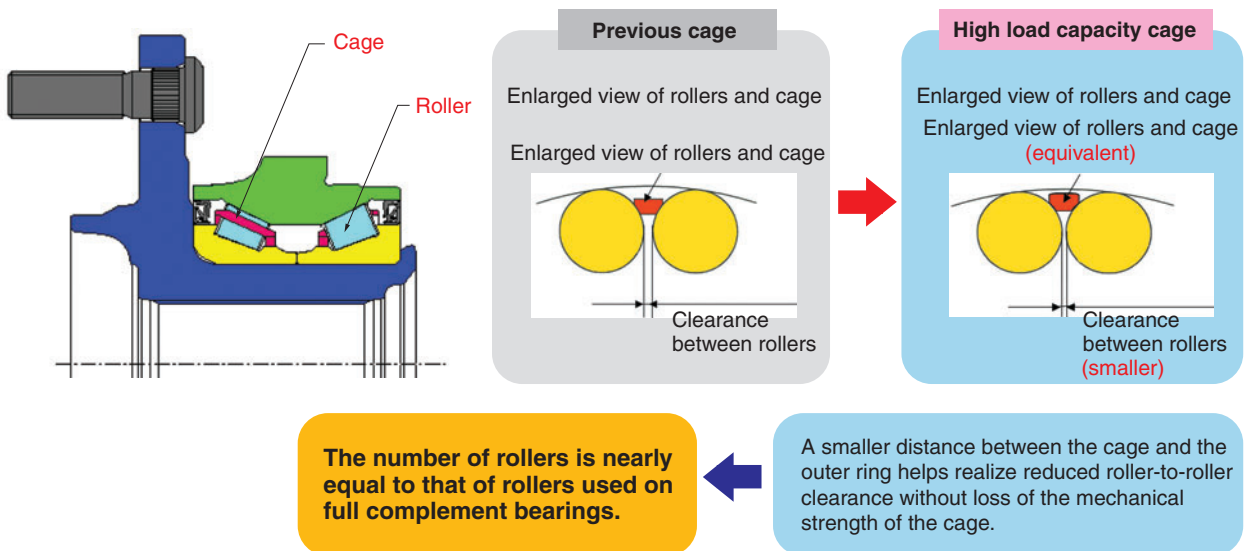

Features

- 20% increase in bearing life (calculated life)
- 7% increase in bearing rigidity

Features

- Wheel bearings for SUVs

Hub Bearing with Built-In Low-Torque Hermetic Seal

Twice the sealing performance and a 15% reduction in running torque in the same seal space through optimization of structure, form and rubber material



Features

- Sealing performance: twice the resistance to muddy water
- Lower torque: 15% decrease in running torque (30% decrease with seal alone)

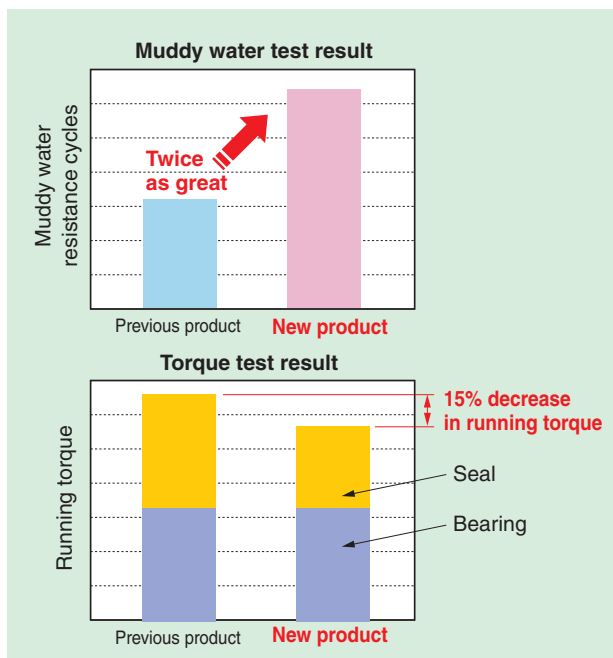

Structure

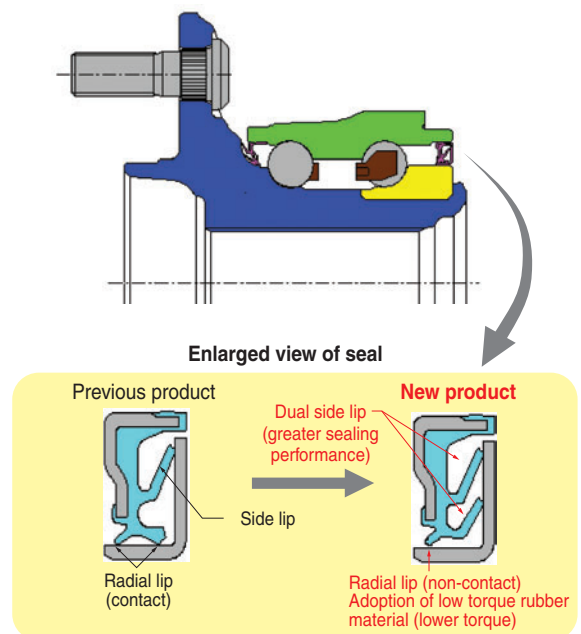

Applications

- Wheel bearings for passenger cars

Hub Bearing with Built-In Active Sensor

No need for adjustment of sensor air gap or machining of knuckle



Features

- No need for adjustment of sensor air gap
- No need for machining work or assembly to secure the sensor to the knuckle
- Protection against flying rocks and prevention of jamming by foreign objects

Means for realization

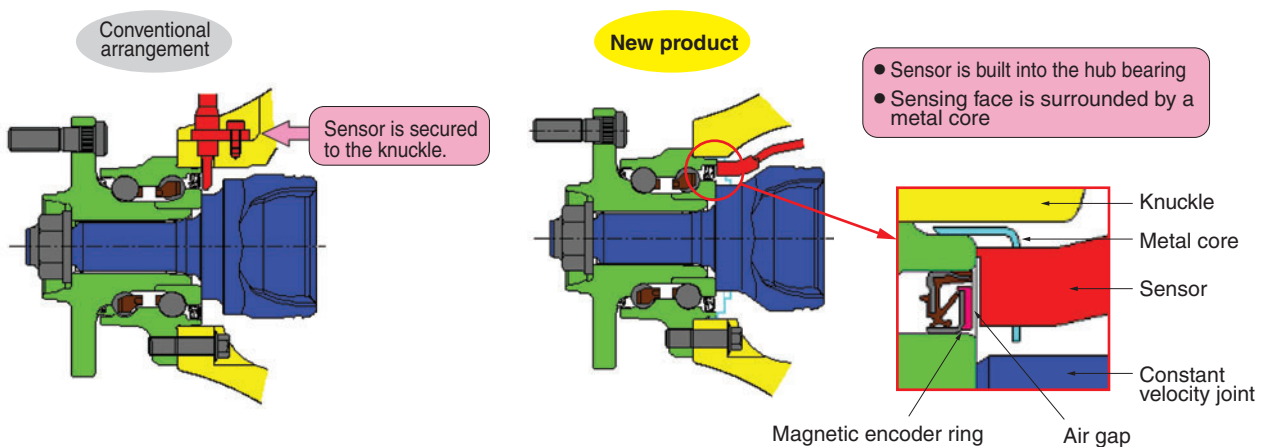

Low-Emission Capable Laminated Conrod Module

- Shell-type needle roller bearing that can operate under minimal lubrication conditions to help comply with emission control
- Realization of compact size with NTN's unique laminated conrod
- Proposal of total VA/VE with modular design involving conrod that incorporates the shell-type needle roller bearings described above

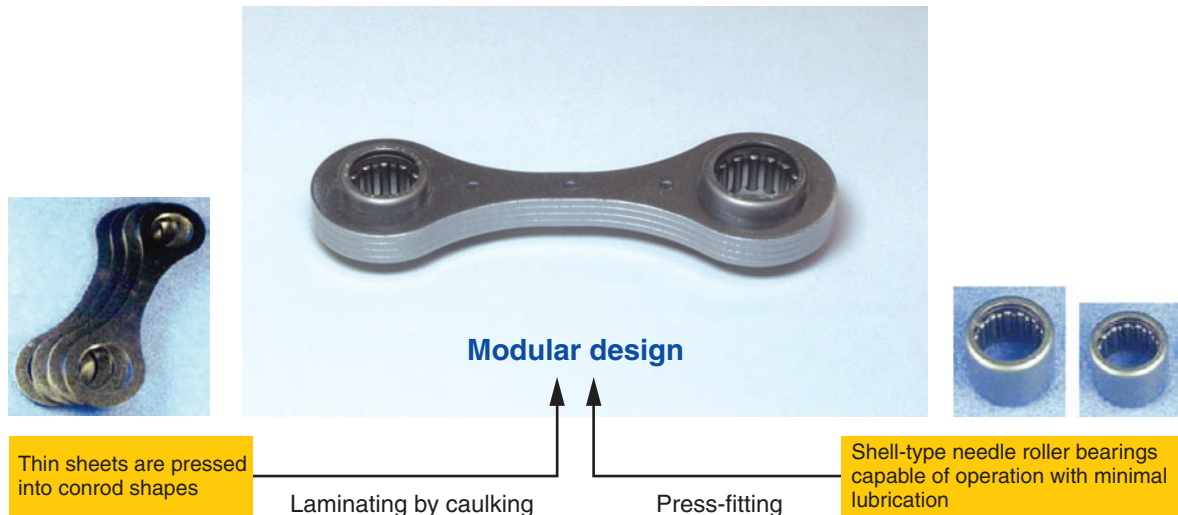

Features

- Through optimized design of the cage used on shell-type needle roller bearings and the higher precision of the outer ring, this conrod boasts excellent anti-seizure performance even under a severely reduced lubrication condition that is four times as demanding as conventional lubrication conditions (75% reduction in the amount of mixed oil).
- This conrod product features a unique laminated construction prepared by pressing thin sheets. As a result, it is very compact, with a minimum width that is 17% (6% in terms of outside dimensions) more compact than conventional conrod products formed by fine blanking techniques.
- NTN offers a modular conrod product that is capable of operation with minimal lubrication. This is prepared by press-fitting shell-type needle roller bearings into its unique laminated conrod component. Being highly functional and compact, this product also serves for VA/VE applications.

Applications

- 2-cycle engines for agricultural machinery (pruning machines, spraying machines, chainsaws, etc.)

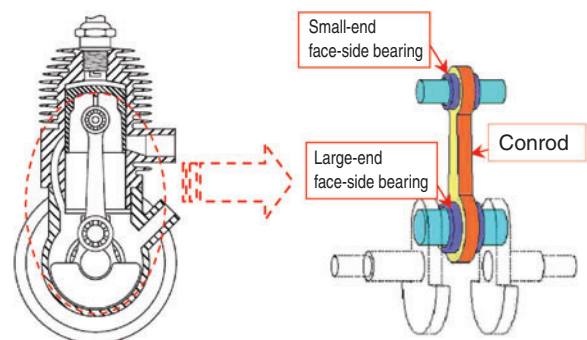

Cross-sectional view of a 2-cycle engine for agricultural machinery

High-Speed, High-Quality Color Filter Repair System

Capable of coping with large-sized substrates, the system features multi-functionality and advanced functions



Features

1) Realization of quick repair

- A dedicated high-speed drive mechanism is provided for repair fluid application
- A combination of a dedicated applicator needle and a repair fluid container is provided for each repair fluid
- No need to rinse the applicator needle; simpler color switching
- The tip of the applicator needle is refilled by repair fluid during application
- No need for separate repair fluid filling

70% reduction in repair time compared to previous repair systems

2) Realization of high-quality repair

- Each applicator needle has a specially treated tip. The amount of the repair fluid applied is adjusted precisely based on the time of contact between the color filter substrate and the applicator needle
- Prevention of overflow of repair fluid to defect-free areas

Improvement in repair quality

Example of repair

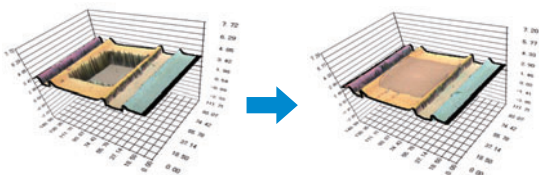

Coating is removed by lasers

Repair fluid is applied

Advantages of the NTN's unique applicator mechanism

① High-speed mechanism specialized for application (for X1, X2, Y, and Z axes)

The time needed for repair is reduced by the high-speed, high-precision drive motion of ultra-compact linear motors.

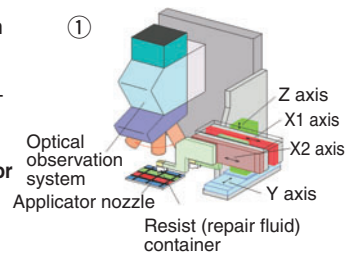

② Provision of four applicator needles

Color switching without rinsing and reduced repair time are realized.

③ Unified support structure for applicator needles and repair fluid containers

Filling of applicator needles with repair fluid is not necessary.

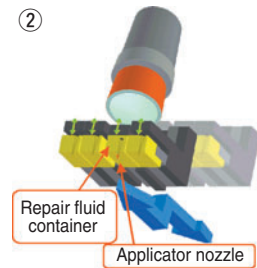

④ Filler-applicator needle

The amount of liquid applied is adjusted in a range from a few picoliters (one trillionth of liter) to tens of picoliters. Repair quality is improved because any defect can be filled with a very small amount of the repair fluid.

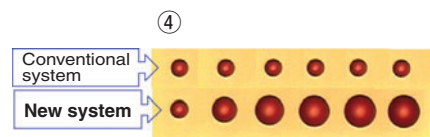

Advanced Functionality Controller for Parts Feeder

Power consumption by parts feeders can be reduced by 30% compared with previous controllers



Features

- 1) **Optimal vibration frequency automatic adjustment function**
 - Automatic adjustment to the most efficient frequency
 - Approximately 30% energy conservation
- 2) **Constant amplitude function allows parts to be transported in an optimal state.**
 - Amplitude regulation: within 3% (under conditions that result in amplitude variation of 10% or greater with previous controllers)
- 3) **No need for a vibration sensor**
 - Work to mount a vibration sensor and lay wires is not necessary
 - The new controller can be easily installed to replace an older controller
 - No problems such as broken vibration sensor leads
 - Reduction of malfunctions

Means for realization

- 1) The drive signal (voltage, current) to the vibrator electromagnet is accurately measured [drive signal measuring device]
- 2) Based on the measured values, (i) deviation from the optimal vibration frequency and (ii) the amount of transportation (vibration amplitude) are estimated [CPU]
- 3) The electromagnet is energized based on the vibration frequency and amplitude ordered by the CPU [inverter]
 - Automatic adjustment of optimal frequency and constant amplitude functions are realized without use of an external vibration sensor

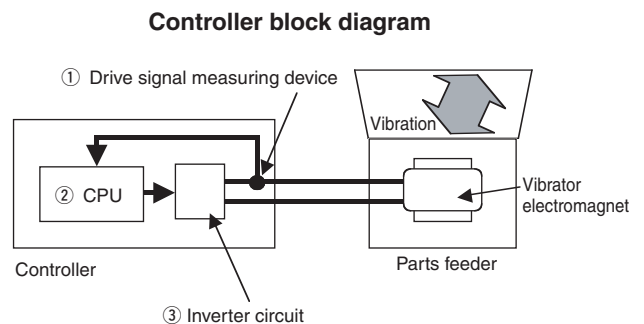
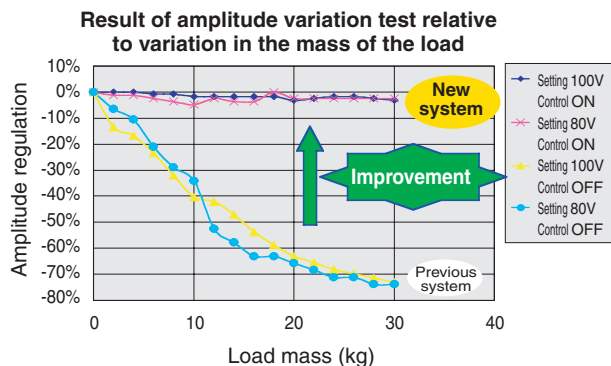

NTN TECHNICAL REVIEW No.74

Printed and published in November 1, 2006

Editor **Kenji Okada**

Publisher **Hitoshi Takai**

Published by NTN Corporation
3-17, 1-chome, kyomachibori, Nishi-ku, Osaka, J apan

Printed by
NISSHA Co., Ltd

**No part of this publication may be reprinted or reproduced
without the prior permission of the copyright owner.**